

SELECTION OF INTERFACE SURFACES
FOR MAGNETIC PICK-UPS

For every magnetic pick-up there is an optimum magnetic surface, whether gears or flat disks with holes, for maximum voltage output. As an aid in determining this design the following illustrations should be helpful.

GEARS*

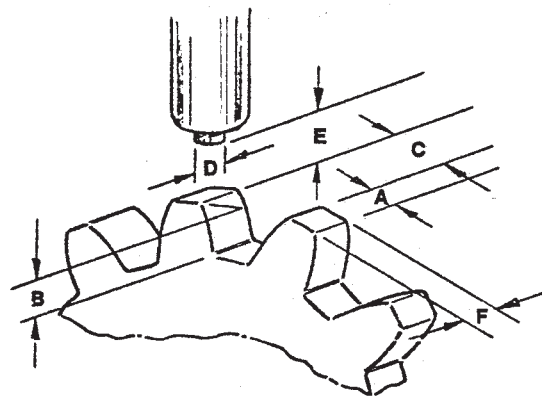

FIGURE 1

In Figure 1 the optimum dimensions of A, B, C and F are given as they relate to D, the diameter of pole piece of the magnetic pick-up being used. The optimum relationship for maximum output is as follows:

- A. (dimension of top of tooth) equal to or greater than D.
- B. (height of tooth) equal to or greater than C.
- C. (space between teeth) equal to or greater than 3 times D.
- D. diameter of pole piece.
- E. (clearance) as close as possible; typically $.38 \pm .13$ [$.015'' \pm .005''$].
- F. (gear thickness) equal to or greater than D.

The above design may not be available in a stock gear. However, it is seldom necessary to have the maximum output. Very close to the maximum output may be generated by conventional stock gears if the tooth width (A, Figure 1) is equal to or greater than the pick-up pole piece diameter D. Gear thickness is not critical as long as it is equal to or greater than the pole piece diameter. For ease of alignment, the thickness should be two or three times the pole piece diameter. The spacing between the pole piece and any magnetic material between "dwell" periods should be equal to or greater than the pole piece diameter. These conditions are approximated when using a standard gear tooth having a diametral pitch of 8 or less. Such large tooth gears are necessary only when maximum output is desired.

FLAT DISK WITH BLIND HOLES OR THROUGH-HOLES DRILLED PARALLEL TO THE SHAFT OR WITH BLIND HOLES DRILLED PERPENDICULAR TO THE SHAFT

When a flat disk is used with blind holes or through-holes, the various dimensional considerations are illustrated in Figures 2, 3, and 4. It is absolutely essential when using a disk with drilled holes that the holes be accurately spaced along the hole circle on the disk. Irregularly spaced holes will cause a phase shift in the magnetic pick-up voltage with a resulting unwanted change in engine speed (the control "reads" the phase shift as a change in engine speed although it actually is not.).

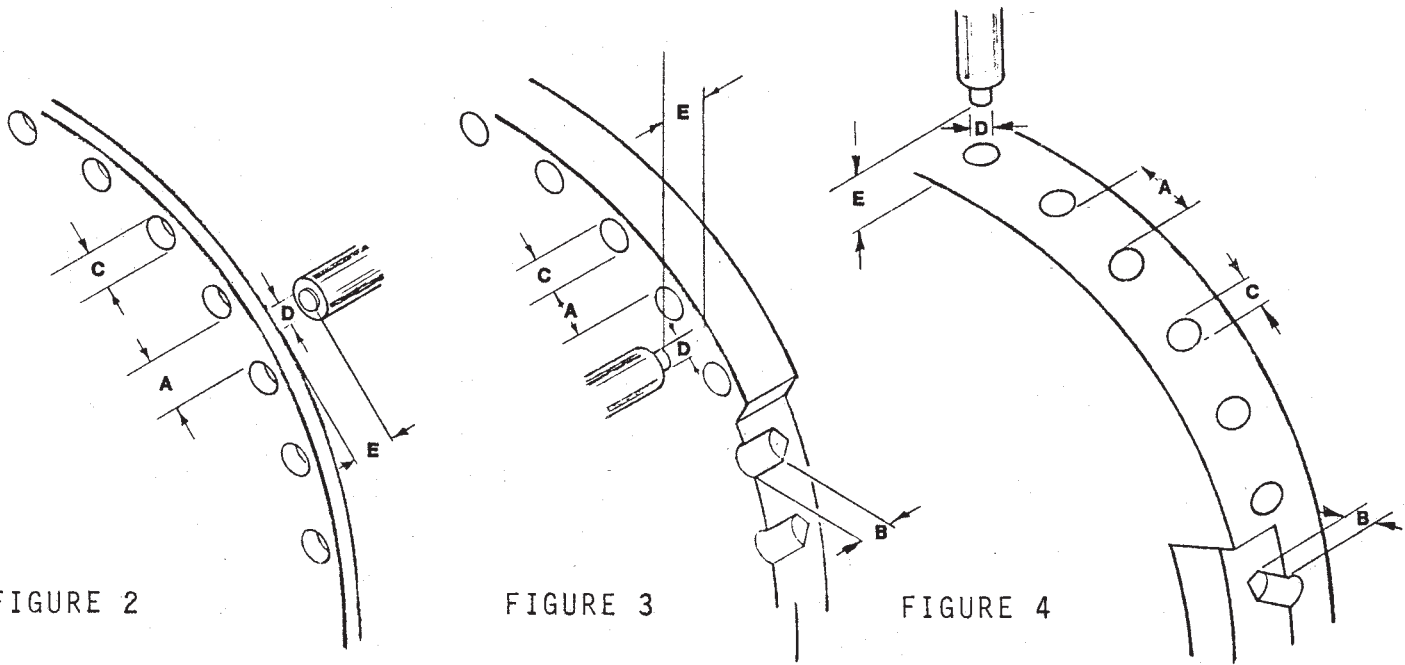

FIGURE 2

FIGURE 3

FIGURE 4

In Figure 2, 3, and 4 the optimum dimensions of A, B, C and E are given as they relate to D, the diameter of the pole piece of the magnetic pick-up. Dimension B does not apply in Figure 2. The optimum relationship for maximum output is as follows:

- A. (space between holes) equal to or greater than D.
- B. (depth of holes) equal to or greater than D.
- C. (diameter of holes) equal to or greater than 3 times D.
- D. diameter of pole piece.
- E. (clearance) $.38 \pm .13$ [$.015'' \pm .005''$].

* Information on gear selection taken from Electro-Products Laboratories Bulletin on Selecting the Proper Gear Size for Magnetic Sensors.

Barber-Colman DYNA Products

1354 Clifford Avenue (Zip 61111) Telephone (815) 637-3000
P.O. Box 2940 Facsimile (815) 877-0150
Loves Park, IL 61132-2940 www.dynaproducts.com
United States of America

In Europe contact: Barber-Colman GmbH
Am Neuen Rheinhafen 4, D-67346 Speyer, Germany
Telephone 06232 29903, Facsimile 06232 299155

In Japan contact: Ranco Japan Ltd.
Shiozaki Bldg. 7-1, 2-chome, Hirakawa-Cho, Chiyoda-Ku
Tokyo 102, Japan
Telephone 3261 4293, Facsimile 3264 4691

An Invensys company

F-16457-1